

LED LAMP SERIES

The LEDS MR16 LED lamps are perfect for retrofit and lighting upgrade solutions. A Direct replacement for 50W Halogen

FEATURES

- Bi-pin lamp base
- High purity aluminum heat sink
- 8 year life or 18,000 hour of continuous use
- 5 - Year Limited Warranty
- ETL Listed

SHIPPING INFORMATION

Unit	Weight	Width	Length	Height
Carton	8.5 kg 18.74 lbs	32 cm 12.60"	59 cm 23.23"	21 cm 8.27"

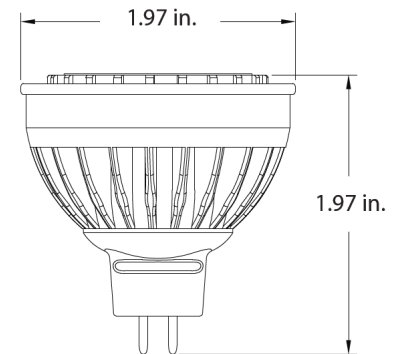

MR16

Order Code	Part Number	Watts	Lumens ¹	CCT ²	Avg Life ³	CRI ⁴	Beam Angle	Voltage
MR0640	MR-6-40-12V-D	6	620	4000	18000	>80	45	12
MR0630	MR-6-30-12V-D	6	620	3000	18000	>80	45	12

This device complies with Part 15 of the FCC Rules. Operation is subject to the following conditions: (1) This device may not cause harmful interference, and (2) this device must accept any interference received, including interference that may cause undesired operation. For FCC Part 15 user information, please see www.fcc.gov

1. Thermally stable typical lumens (+/- 10%)
2. Thermally stable CCT (+/- 10%)
3. Average life based on 70% lumen maintenance
4. Color rendering index/Ra